



Features

- High Stability
- Temperature Insensitive
- Compensated Linear Response

Applications

- AOM



Warning: The device needs to be mounted on a heat sink or on a metal frame

The AOMD is a high-performance acoustic modulator driver designed to optimize optical output response to an electrical control signal, featuring four working mode setting switches for application-specific adjustments. It has three control modes: digital TTL, analog 0-1V and 0-5V, and digital/analog, in which the analog signal controls the digital intensity. The AOMD generates a temperature-insensitive wave at a fixed frequency that matches the acoustic-crystal resonance, forming a Bragg grating within the crystal for efficient light diffraction. It delivers up to 3W of driving power with a 24V DC input. Due to the sinusoidal power dependency of Bragg diffraction, the acousto-optic modulator (AOM) exhibits inherent nonlinearity in its response to the input signal. To mitigate this effect and enhance linearity, the AOMD integrates a pre-distortion circuit to improve the linearity of both the digital and analog optical responses, though with some limitations in profile matching. Each fiber-coupled acoustic modulator is precisely aligned to the electrically generated grating, optimizing light collection with minimal insertion loss at the output fiber. A pre-set impedance matching screw minimizes optical loss for each Agiltron device while allowing field adjustments if necessary. The SMA modulation control input varies the diffraction amplitude, resulting in modulation of the output light intensity for precise optical control.

To prevent damage, the AOMD must not be powered when open or shorted, and proper grounding is essential for optimal performance. As the unit generates heat, it must be mounted on a metal structure using fixing screws for heat removal.

The rise and fall time of the Acousto modulator is proportional to the laser beam size only.

Specifications

Parameter	Min	Typical	Max	Unit
Frequency		40 ± 0.01%		MHz
Frequency Stability	-10		+10	ppm/°C
Driving Power [1]	0.1		3	W
Modulation Bandwidth	DC	10	15	MHz
Supply Voltage		+24		V
Supply Current		0.7		mA
VSWR		1.5/1		
Voltage Standing Wave Ratio		1.2 : 1		
Rise/Fall Time		2.5	6	ns
Harmonic Distortion		Analog		
Analog Control Signal	0		5	V
Digital Control Signal (TTL)	< 0.8		> 2	V
Output Impedance		50		Ω
AOM Interface		SMA		
Control Interface		SMA		
Operating Temperature	-5		55	°C
Storage Temperature	-45		85	°C

Notes:

[1]. This is for generating internal grating. The power level is preset, but can be adjusted with a screw driver through the side hole

Legal notices: All product information is believed to be accurate and is subject to change without notice. Information contained herein shall legally bind Agiltron only if it is specifically incorporated into the terms and conditions of a sales agreement. Some specific combinations of options may not be available. The user assumes all risks and liability whatsoever in connection with the use of a product or its application.

Rev 07/03/26

DATASHEET

Mechanical Dimensions (mm)

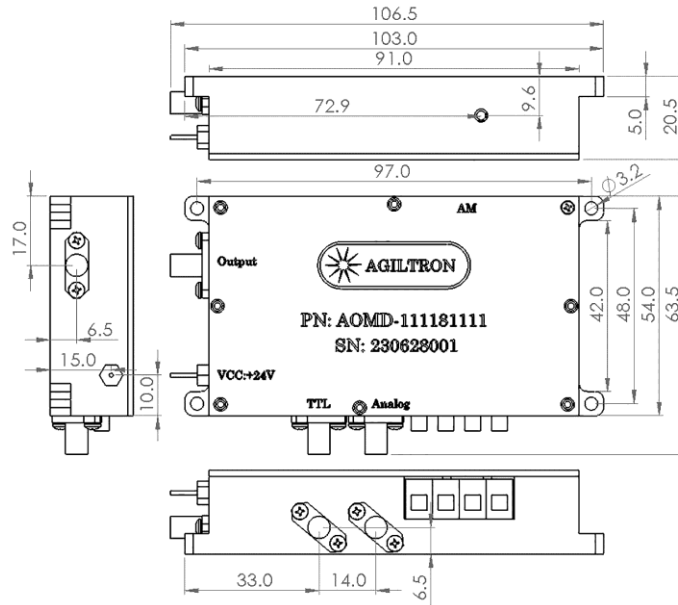

*Product dimensions may change without notice. This is sometimes required for non-standard specifications.

Connection Diagram

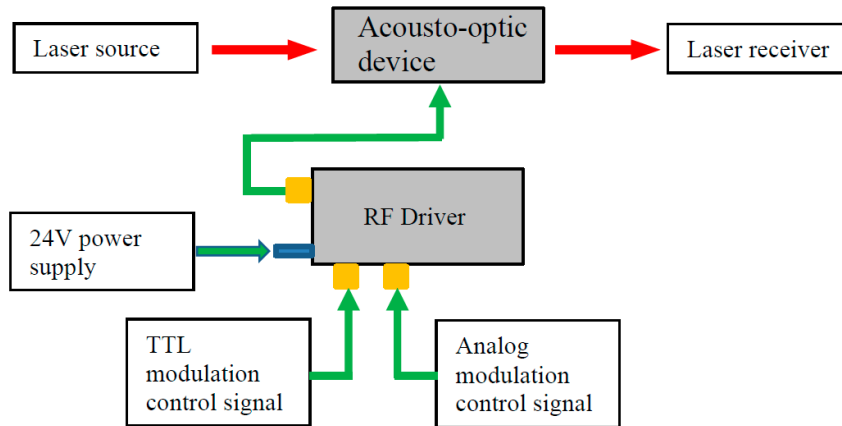

Acousto-Optic Modulator Drivers – 40MHz



3W

DATASHEET

Benchtop AOMD with AOMF (Package option 2 – Box)

Benchtop Box Mechanical Dimension

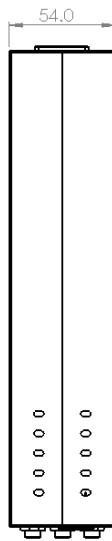
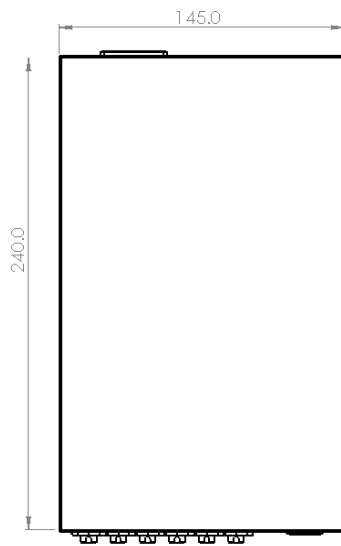

*Product dimensions may change without notice. This is sometimes required for non-standard specifications.

DATASHEET

Installation Instruction

- Heat Dissipation:** The product utilizes conduction cooling and must be installed on a metal structure using fixing screws. The installation surface should be flat, with adequate thickness and size for effective heat dissipation. Ensure sufficient clearance around and above the product to facilitate heat dissipation.
- Power Connection:** Operates on a +24V DC power supply. The power connector includes a through-core capacitor: Core of the capacitor → Connect to the positive terminal of the power supply. Ground plate of the capacitor → Connect to the negative terminal via a wire. The +24V connector is a 0.9mm diameter legacy pin, with the ground ear pin integrated into this pin.
- Signal Output & Impedance Matching:** The signal output port has a characteristic impedance of 50Ω. Important: Do not turn on the power if the signal output interface is open or short-circuited, as this may damage the product.
- Grounding & Performance Stability:** Ensure proper grounding to maintain optimal performance and minimize interference.
- Output Power Adjustment:** Output power is adjusted via a slotted multi-turn potentiometer: Clockwise rotation → Increases output power. Counterclockwise rotation → Decreases output power. The adjustment range exceeds 15 dB.
- Static Protection:** The product is sensitive to static electricity; appropriate ESD protection should be observed during handling and use.

Typical Output Spectrum

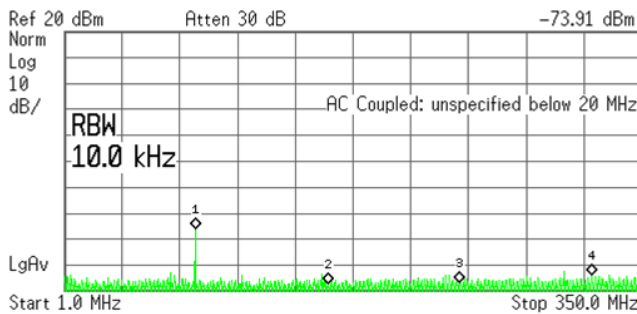

0 Volts Input

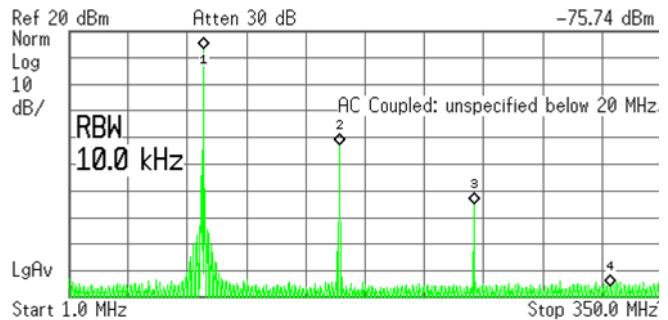

5 Volts Input

Ordering Information (Part Number)

	<input type="checkbox"/>	<input type="checkbox"/>	<input type="checkbox"/>	1	4	1	1	<input type="checkbox"/>	1
Prefix	Type	Power	Frequency	Package					
AOMD-	Analog = 11 Digital = 22 Both = 33	3W = 3 100W = H	40MHz = 4	Module = 1 Box ^[1] = 2 Special = 0					

[1]. This is a laboratory benchtop AOM driver that integrates a power supply with 110-240V AC power. It has SMA control signal input and a power adjustment knob on the front panel.

Operation Instruction/Manual

1. Laser wavelength

An acousto-optic modulator is wavelength sensitive, i.e., a narrow-band device. The wavelength of input laser beam must match the nominal wavelength of modulator. Any wavelength deviation of input laser beam will cause significant increase of insertion loss.

2. Optical fiber connection

All connectors need to be properly cleaned and make sure connector type matches.

3. RF Output connection

Use the provided SMA cable to connect the 'RF Output' of driver to acousto-optic modulator.

4. Power supply connection

Connect the 'Vcc +24V' and the negative plate of driver to a power supply. **Incorrect connection to positive and negative electrodes will cause severe damage of driver and modulator**

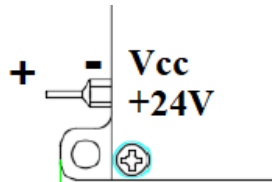

5. Analog modulation mode

- Put all in the down position as shown below.

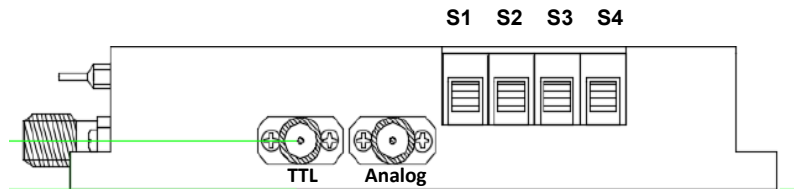

- Connect the analog control to the Analog. The driver will work with an analog response.

6. Digital TTL modulation mode

- Pull S4 in the up position and the rest of switches in the down position as shown below.

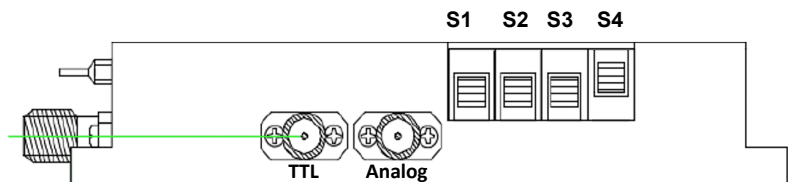

- Connect the TTL control to the TTL input. The driver will work with sharp on/off TTL response.

Operation Instruction/Manual

7. Digital/Analog modulation mode

- The driver has a digital/analog modulation mode in which the RF output is control by both digital TTL and analog inputs.
- Put all switches in the low position as shown below

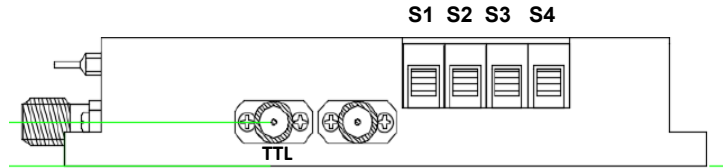

- Connect TTL signal into the TTL SMA port, and connect a 0-5V analog input to the Analog SMA port.
- The ‘TTL’ port of the driver is optimized for sharp on/off response that is triggered by standard TTL input signal. In this operation mode the Analog port provides amplitude control of the TTL response. The relationship is illustrated below. The RF output sharp on/off is controlled by the TTL input and its magnitude is controlled by the Analog input level.

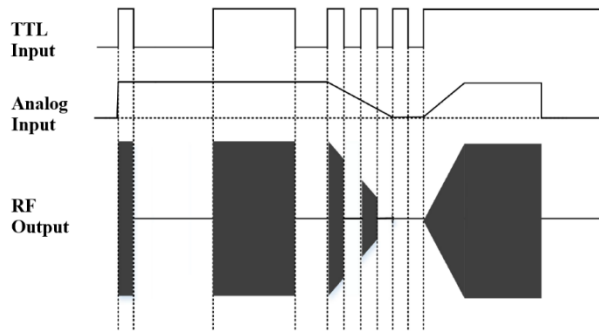

8. Mode control summary

A group of 4 switches are used for control of driver’s working mode.

Switch #	Position	Working Mode	TTL	Analog	Both
S1	Up	TTL high level to enable RF output	Either	●	Either
	Down	TTL low level to enable RF output			
S2	Up	TTL input disabled, block RF output	●	●	●
	Down	TTL input enabled, RF output depends on TTL & analog inputs			
S3	Up	0 ~ 5V input range of analog modulation	●	●	●
	Down	0 ~ 1V input range of analog modulation (recommended, essential for 80M AOMD)			
S4	Up	Analog input disabled	●	●	●
	Down	Analog input enabled			

9. Adjustment of driver output power

Warning: The RF output power of driver has been matched with acousto-optic device in factory. Please DO NOT adjust it unless necessary.

When the RF output power of driver has to be adjusted a flat-head screw driver can be used to turn the small knob masked as 'AM' located on the side of driver. Turn it clockwise to increase power, and counterclockwise to decrease power.

Application Notes

- **Output impedance**
50Ω
- **Driver cannot run without a load or with its output shorted.**
Acousto-optic device and its driver work at high frequency. If driver is powered on when there is no load connected to it, such as an acoustic-optic modulator, then it will be damaged.
A shorted output connection will also cause damage of driver.
- **Heatsink for driver**
The driver will be heated up in work condition. A heatsink or a big piece of metal plate is strongly recommended for driver installation. High temperature will cause damage to driver.
- **Ensure driver is well grounded to achieve desired performance.**
- **Use caution when handle optical fibers.**
- **Always cover connectors with caps when they are unplugged**